

TWO NOTES ON FEATURE INHERITANCE: A PARAMETRIC VARIATION IN THE DISTRIBUTION OF THE EPP*

Mamoru Saito
Nanzan University

1. Introduction

Chomsky (2008) proposes an analysis where ϕ -features are located in phase heads and are inherited by their complements. This analysis is motivated by the fact that T, for example, carries ϕ -features only in the presence of C. The feature inheritance mechanism is illustrated in (1).

- (1) [C [TP NP [T [vP NP [...
 { ϕ , edge} \nearrow

T with unvalued ϕ -features probes and enters into Agree relation with an NP, and the edge feature of T raises the NP to its Spec. This paper reports a preliminary investigation into how this applies in Japanese, which arguably lacks ϕ -feature agreement. As the edge feature in question requires the Spec position to be filled, I use the more traditional term, the EPP, in its place.

If Japanese indeed lacks ϕ -feature agreement as argued in Kuroda (1988), Saito (2007), and Şener and Takahashi (2010), among many others, then a few possibilities arise. If the presence of the EPP (edge) feature on phase heads is contingent on that of ϕ -features, then phase heads in Japanese may lack both ϕ and EPP. On the other hand, if the presence of EPP is independent of that of ϕ , then phase heads in Japanese may only carry the EPP. In this case, there are two further possibilities with feature inheritance. First, the EPP on phase heads may be transmitted to their complement heads exactly as in English. Second, it may be retained by the phase heads. This is plausible if ϕ -features are the locus of feature inheritance and the EPP is “pied-piped” in ϕ -feature agreement languages only because formal features form an inseparable bundle. In what follows, I present two pieces of evidence for this last possibility. That is, I argue that phase heads in Japanese carry and retain the EPP feature. I suggest further that C and v are equipped with the EPP regardless of whether they constitute phase heads. This is in line with Rothstein’s (2001) proposal that the EPP reflects the required predication relations in sentential domains.

The two pieces of evidence alluded to above both originate in my critique of Miyagawa’s

* The material in this paper was presented in syntax seminars at Keio University, the University of Connecticut and Nanzan University. I thank the audiences there, including Hisa Kitahara, Željko Bošković and Yuji Takano, for helpful comments.

(2001, 2003) analysis of subject-negation scope interaction. Two of his core examples are shown in (2).

- (2) a. Zen'in-ga sono tesuto-o uke-na-katta (yo / to omo-u)
 all-NOM that test-ACC take-Neg.-Past Part COMP think-Pres.
 'All didn't take that exam' (all > not, *not > all)
- b. Sono tesuto-o_i zen'in-ga _{t_i} uke-na-katta (yo / to omo-u)
 that test-ACC all-NOM take-Neg.-Past Part COMP think-Pres.
 'That exam, all didn't take' (all > not, not > All)

The subject *zen'in* 'all' takes scope over negation in (2a). On the other hand, in (2b), where the object is scrambled over the subject, *zen'in* may take narrow scope with respect to the negation. Miyagawa's analysis, which is discussed in more detail in the following section, is that the subject in (2a) is in TP Spec, satisfying the EPP requirement of T, and hence, asymmetrically c-commands the negation. In (2b), on the other hand, the object may be in TP Spec, allowing the subject to stay in ν P Spec. This leads to the narrow scope reading of the subject.

I presented a slight modification of this analysis in Saito (2009, 2010), arguing that the locus of the EPP is not T but Pred, which is the lowest head in the recursive C projections. Then, *zen'in* in (2a) is in PredP Spec, while that in (2b) may remain in TP Spec because the scrambled object can satisfy the EPP requirement of Pred. The remaining question in this revised analysis was why Pred carries the EPP instead of T in Japanese. But this is precisely what is expected if T does not inherit the EPP from C in Japanese. I go over the arguments for this revised analysis and discuss its implication for feature inheritance in more detail in the following section. Another issue I raised with Miyagawa's analysis concerns the definition of 'subject'. It is well known that the Japanese reflexive *zibun* is subject-oriented, and 'subject position' is standardly defined as TP Spec. This poses a potential problem for Miyagawa's analysis as a scrambled object never qualifies as the antecedent of *zibun*. However, I argued in Saito (2009) that the situation is a little more complex. More specifically, I argued that ν is always equipped with the EPP in Japanese and that the possible antecedents of *zibun* are those phrases that satisfy the EPP requirement of ν .¹ This leads to the question why ν in Japanese carries the EPP. Again, the absence of feature inheritance provides an answer. I present this argument with a few additional consequences in Section 3. Section 4 concludes the paper.

2. The "Clause-Initial Position" is Spec, CP

In this section, I first go over Miyagawa's (2001, 2003) analysis of the subject-negation scope interaction, pointing out a few potential problems. Then, I present the revised analysis in Saito (2009, 2010) and discuss how it leads to evidence for the absence of feature

¹ The hypothesis is presented more explicitly with further supporting arguments in Takano (2010).

inheritance in Japanese.

2.1. Miyagawa 2001, 2003 on the Subject-Neg Scope Interaction

Miyagawa's data in (2) are repeated in (3).

- (3) a. Zen'in-ga sono tesuto-o uke-na-katta (yo / to omo-u)
all-NOM that test-ACC take-Neg.-Past Part COMP think-Pres.

'All didn't take that exam' (all > not, *not > all)

- b. Sono tesuto-o_i zen'in-ga t_i uke-na-katta (yo / to omo-u)
that test-ACC all-NOM take-Neg.-Past Part COMP think-Pres.

'That exam, all didn't take' (all > not, not > All)

As noted above, the subject takes scope over negation in (3a), and the scrambling of the object over the subject creates a scope ambiguity as in (3b). Miyagawa assigns the structure in (4a) to (3a).

- (4) a.

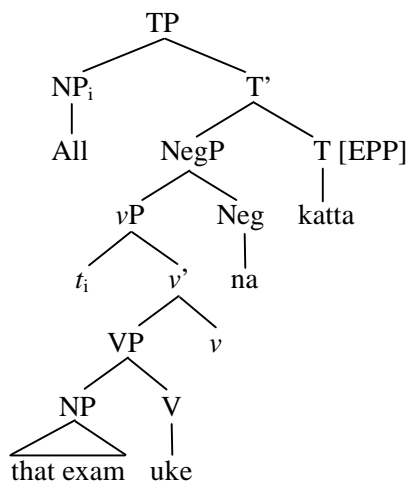

- b.

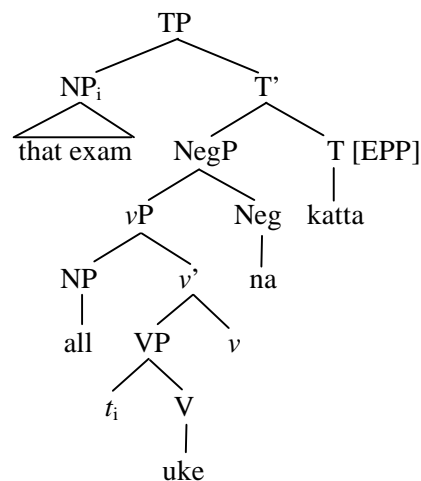

The subject asymmetrically c-commands Neg in (4a), and hence, *zen'in* 'all' takes wide scope over negation in (3a). (3b) can be derived by A'-scrambling, which, according to Miyagawa, involves focusing and adjunction to TP. In this case, the scope relation of the subject and negation remains the same. But he argues that the example can also be derived by A-scrambling as in (4b). His hypothesis is that A-scrambling is movement to TP Spec and consequently, the scrambled phrase satisfies the EPP requirement of T. Then, the subject can remain in vP Spec and take narrow scope with respect to negation. Thus, the scope ambiguity of (3b) follows.

As Miyagawa points out, it is not that scrambling always has an effect on the scope of the subject as in (3b). In (5), for example, the embedded object is scrambled out of a CP to the initial position of the matrix clause.

- (5) Syukudai-o_i zen'in-ga [_{CP} sensei-ga *t_i* das-u to]
 homework-ACC all-NOM teacher-NOM assign-Pres. COMP
 omow-ana-katta (yo)
 think-Neg-Past Part

‘Homework, all did not think that the teacher will assign’ (All > Not, *Not > All)

This example sharply contrasts with (3b) and does not allow the narrow scope reading of *zen'in* with respect to negation. This is predicted nicely by the analysis. As the scrambling is out of the embedded CP, it cannot be A-scrambling to TP Spec. Hence, the matrix subject must move to this position to satisfy the EPP requirement of T. This yields the wide scope reading of the subject.

Although Miyagawa’s analysis is quite elegant, a few questions can be raised. First, it is assumed that a quantified NP in TP Spec takes scope over negation because of their structural relation. But it is known that this assumption does not hold in English. Thus, (6) exhibits scope ambiguity.

- (6) Everyone didn’t take the exam (Every > Not, Not > Every)

Second, the analysis of A-scrambling as movement to TP Spec necessitates the reconsideration of the notion ‘subject’, as mentioned above. The Japanese reflexive *zibun* is subject-oriented. In (7), for example, only the subject *Hanako* qualifies as the antecedent of *zibun*.

- (7) Hanako_i-ga Taroo_j-o zibun_{i,*j}-no heya-de sikat-ta
 H.-NOM T.-ACC self-GEN room-in scold-Past

‘Hanako scolded Taroo in her room’

Given the standard definition of ‘subject position’ as TP Spec, it is then predicted that a scrambled object should be a possible antecedent for *zibun*. But (8) shows that this prediction is not borne out.

- (8) Taroo_j-o [Hanako_i-ga *t_j* zibun_{i,*j}-no heya-de sikat-ta]
 T.-ACC H.-NOM self-GEN room-in scold-Past

‘Hanako scolded Taroo in her room’

In this example also, *Hanako* is the only possible antecedent for *zibun*. It is necessary then to pursue an alternative analysis of scrambling or to redefine ‘subject’ in the relevant sense. I argue in Section 3 that we must do both.

Finally, pairs like (9) constitute counterevidence for Miyagawa’s analysis.

- (9) a. Zen'in-ga zibun-zisin-ni toohyoosi-na-katta (to omo-u)
 all-NOM self-self-DAT vote-Neg.-Past COMP think-Pres.

'Everyone did not vote for herself/himself' (all > not, *not > all)

- b. Zibun-zisin-ni_i zen'in-ga t_i toohyoosi-na-katta (to omo-u)
 self-self-DAT all-NOM vote-Neg.-Past COMP think-Pres.

'For herself/himself, everyone did not vote' (all > not, not > all)

These examples indeed confirm his generalization. The sentence-initial subject *zen'in* takes wide scope over negation in (9a). In (9b), the (dative) object is scrambled across the subject and a scope ambiguity emerges. But note that the scrambled phrase is a reflexive in this example. According to Miyagawa's analysis, the narrow scope reading of the subject obtains with the structure in (10a).

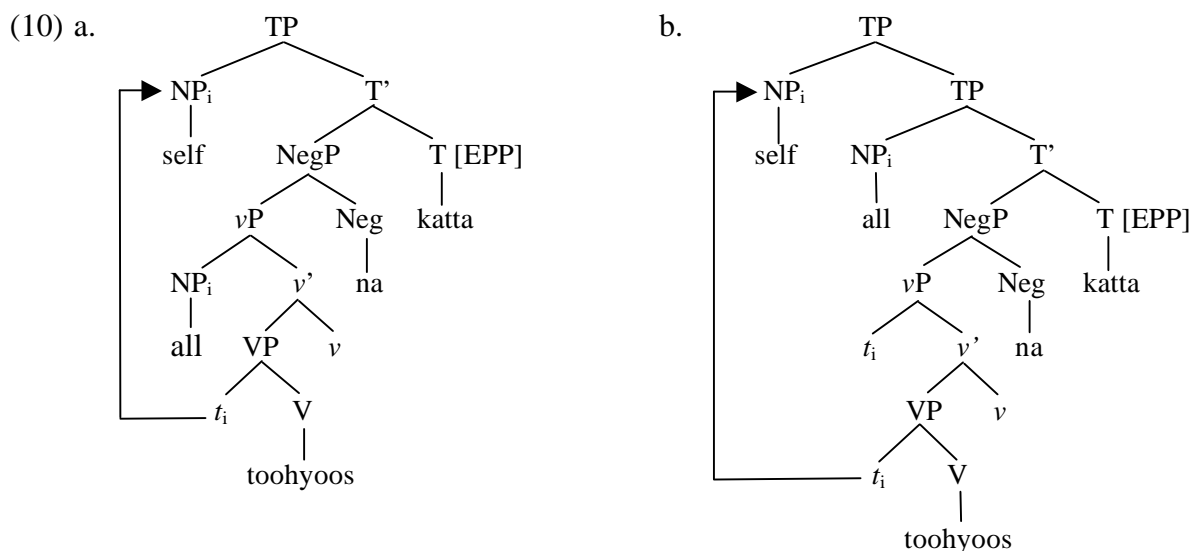

As the object moves to TP Spec and satisfies the EPP requirement of T, the subject can remain in v P Spec and take narrow scope with respect to negation. But the structure is in violation of Condition (C) as the object A-binds the subject. In order to avoid this, the structure in (10b) must be assumed where the object is preposed by A'-scrambling. But then, it is predicted incorrectly that *zen'in* must take scope over the negation.

In the following subsection, I briefly discuss the modification of Miyagawa's analysis proposed in Saito (2009, 2010). It basically maintains his insights but proposes to shift the locus of the EPP to a higher functional head.

2.2. The Role of C in the Slightly Revised Analysis

The EPP feature on T plays a crucial role in Miyagawa's analysis. When the subject is sentence-initial, it is in TP Spec and satisfies the EPP requirement of T. On the other hand, when a scrambled object moves into TP Spec and checks the EPP feature, the subject may remain in a lower position. In Saito (2009, 2010), I proposed that the locus of the relevant

EPP is not T but C.² In this subsection I show how this proposal solves most of the potential problems mentioned above.

Let us start with the reexamination of (9a-b). If the relevant EPP feature is on C instead of T, the structures of these examples would be as in (11a-b) respectively.³

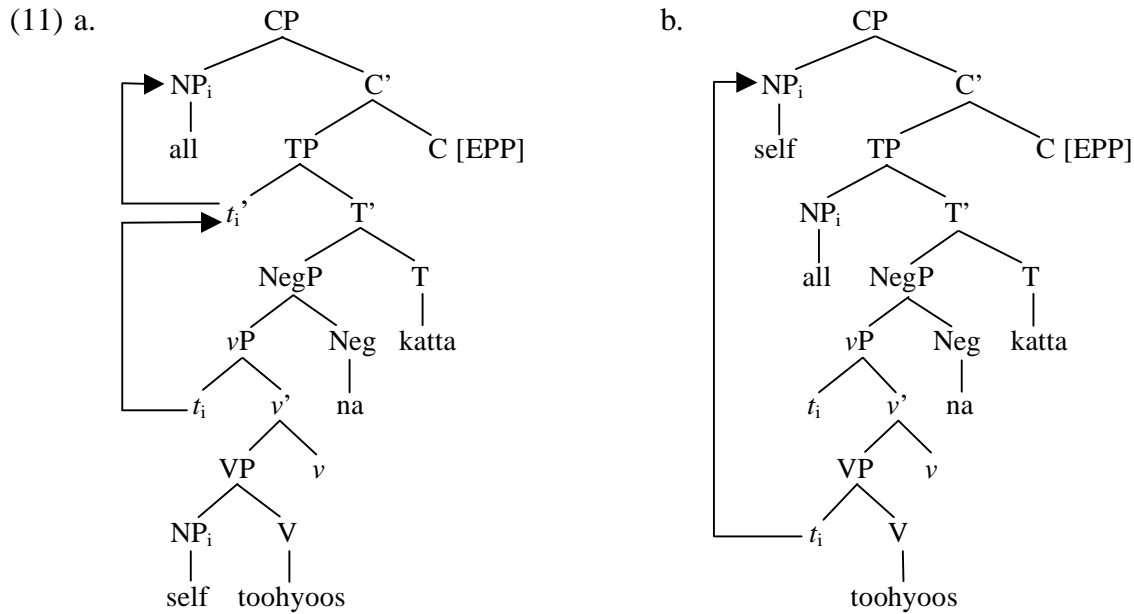

Let us first assume that a phrase in TP Spec scopally interacts with negation. This makes the analysis consistent with the scope ambiguity observed in the English (6). If the locus of the EPP is C, the subject in (9a) should be in CP Spec, as indicated in (11a). As it is out of the TP, it takes scope over negation. In (9b), on the other hand, the object moves to CP Spec as in (11b) to satisfy the EPP requirement of C. This allows the subject to remain in TP Spec and the scope ambiguity between the subject and negation obtains exactly as in the English (6). Further, the example is not in violation of Condition (C), as the preposed object is in CP Spec, which is an A'-position. This analysis is basically Miyagawa's with slight adjustments. But it does not face the problems mentioned in the preceding subsection.

Recall that long scrambling out of CP does not yield the narrow scope reading of the matrix subject. The relevant example in (5) is repeated below as (12).

² In Saito (2010), I called the relevant C 'Pred', speculating that it corresponds to the lowest C 'Subject' in the recursive CP system proposed in Rizzi (1997). It is to be distinguished with higher Cs such as Force.

³ I assume here that the subject moves to TP Spec for its nominative Case to be licensed, but this assumption is not crucial.

- (12) Syukudai-o_i zen'in-ga [_{CP} sensei-ga t_i das-u to]
 homework-ACC all-NOM teacher-NOM assign-Pres. COMP
 omow-ana-katta (yo)
 think-Neg-Past Part

'Homework, all did not think that the teacher will assign' (All > Not, *Not > All)

This indicates that an embedded object cannot satisfy the EPP requirement of the matrix C, and consequently, the matrix subject should move to CP Spec. In Saito (2009, 2010), I presented an analysis for this on the assumption that the EPP of C attracts the closest phrase to its Spec position. The analysis is based on the derivational interpretation of scrambling chains originally proposed in Saito (2003). But as the precise analysis is not important for the purpose here, I outline a simplified account below.

If the EPP feature of C attracts the closest phrase, the derivation of (9b) should be more precisely as in (13).

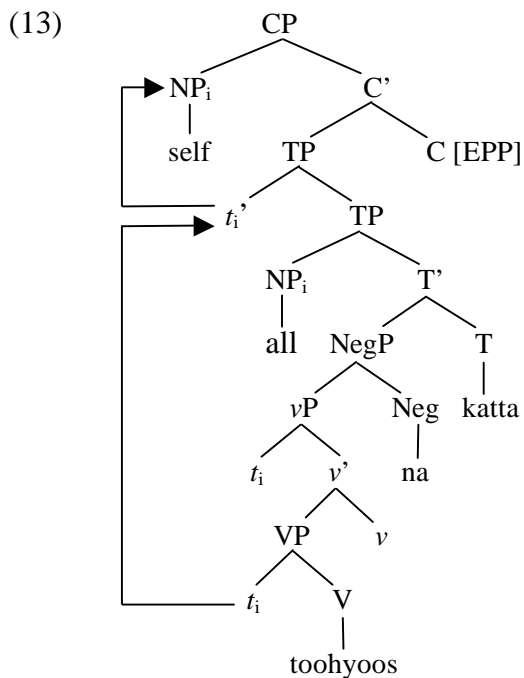

That is, the movement of the object to CP Spec should be mediated by scrambling to the edge of TP. This is so because the subject would be attracted to CP Spec as the closest phrase without this scrambling. Suppose now, as seems reasonable, Specs of T are A-positions as opposed to Specs of C, which are already assumed to be A'-positions. Then, an embedded object cannot undergo scrambling to the edge of the matrix TP. As it has to first move to the edge of the embedded CP phase, which is an A'-position, further movement to the edge of the matrix TP would be an improper movement from an A'-position to an A-position. Consequently, the embedded object cannot be located in a position to be attracted by the EPP feature of the matrix C, and the matrix subject moves to CP Spec instead. The subject, being in CP Spec, takes scope over negation.

The structure of the relevant parts of (12), then, should be as in (14).

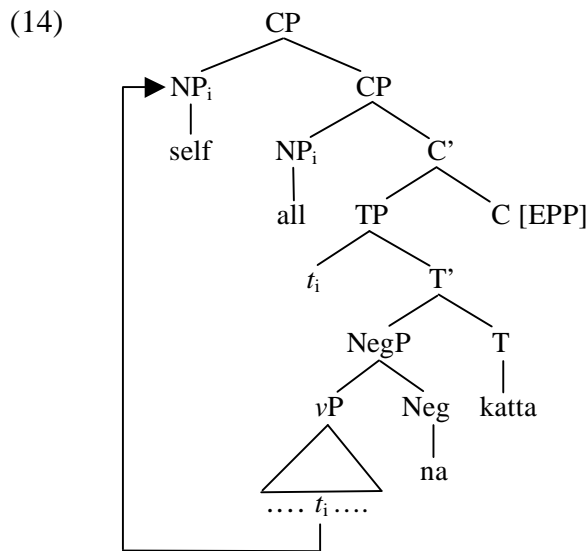

The EPP feature of C attracts the subject to its Spec, and the embedded object is raised to the outer CP Spec by A'-scrambling. According to this revised analysis of Miyagawa's paradigm, scrambling is a uniform operation. A-scrambling is movement to an outer Spec of T while A'-scrambling targets the outer Spec of C. Neither takes place to satisfy an EPP requirement. But A-scrambling can feed an EPP driven movement to CP Spec.

This analysis implies that the locus of EPP is C in Japanese while it is T in English.⁴ Then, the remaining question is why this difference obtains. Here, the hypothesis that ϕ -features are subject to feature inheritance and the EPP is only "pied-piped" provides a direct answer. In English, T inherits the ϕ -features from C, and hence, inherits the EPP as well. In Japanese, on the other hand, there is no ϕ -feature agreement and C does not have ϕ -features to begin with. Consequently, C retains the EPP feature.

If this analysis is on the right track, we should expect feature inheritance to be absent in the ν -V domain as well in Japanese. In the following section, I argue that the prediction is indeed borne out.

3. "Subjecthood" and the EPP Feature on ν

Among the potential problems for Miyagawa's analysis mentioned in the preceding section, there is one that I have not examined so far. It has to do with the definition of 'subject position'. The relevant examples in (7)-(8) are repeated as (15a-b) below.

⁴ In Saito (2009, 2010), I assumed that the EPP feature is on T as well as C in Japanese. But the analysis requires the feature only on C.

- (15) a. Hanako_i-ga Taroo_j-o zibun_{i,*j}-no heya-de sikat-ta
 H.-NOM T.-ACC self-GEN room-in scold-Past
 ‘Hanako scolded Taroo in her room’
- b. Taroo_j-o [Hanako_i-ga *t_j* zibun_{i,*j}-no heya-de sikat-ta]
 T.-ACC H.-NOM self-GEN room-in scold-Past
 ‘Hanako scolded Taroo in her room’

As these examples show, *zibun* is subject-oriented and a scrambled object does not count as a subject. According to Miyagawa’s analysis, *Hanako* in (15a) checks the EPP feature of T and so can the scrambled object *Taroo* in (15b). It is therefore not immediately clear how these two can be distinguished.

I took up this issue in Saito (2009) and argued that the problem is more complex than examples like (15) indicate. More specifically, I argued that *v* is equipped with the EPP feature in Japanese and what qualifies as the antecedent of *zibun* is a phrase that satisfied the EPP requirement of *v*. Based on this, I went on to show that there is A-scrambling that is not driven by the EPP because scrambling to the *v*P edge has A-properties and yet does not make the scrambled phrase a possible antecedent for *zibun*. In this section, I briefly go over the relevant parts of these arguments and show that they support the absence of feature inheritance in the *v*-V domain in Japanese. I first discuss the distribution of the possible antecedents of *zibun* and present evidence that *v*P spec, instead of TP Spec, is the relevant position. Then, I argue that *v* is equipped with an EPP feature and relate this conclusion to the absence of feature inheritance.

3.1. A Reexamination of Possible Antecedents for *Zibun*

First of all, there is fairly clear evidence that an external argument in *v*P Spec counts as a subject in the relevant sense. It is well known since Kuroda (1965) that causative sentences in Japanese involve clausal embedding despite the appearance to the contrary.⁵ Thus, *zibun* can take not only the causer but also the causee as its antecedent in (16).

- (16) Hanako_i-ga Taroo_j-ni [zibun_{i,j}-no sensei]-o hihans-ase-ta (koto)
 H.-NOM T.-DAT self-GEN teacher-ACC criticize-cause-Past fact
 ‘Hanako made Taroo criticize her/his teacher’

This is unexpected if (16) is a simple sentence with *Hanako* as the subject and *Taroo* as the indirect object because *zibun* is subject-oriented. The examples in (17) confirm the subject orientation of *zibun*.

⁵ A detailed description on this is provided also by Kuno (1973) and Oshima (1979), among many others.

- (17) a. Taroo_i-ga Hanako_j-ni [zibun_{i,*j}-no atarasi-i sensei]-o syookaisi-ta (koto)
 T.-NOM H.-DAT self-GEN new-Pres. teacher-ACC introduced fact
 ‘Taroo introduced his new teacher to Hanako’
- b. Taroo_i-ga Hanako_j-o [zibun_{i,*j}-no atarasi-i sensei]-ni syookaisi-ta (koto)
 T.-NOM H.-ACC self-GEN new-Pres. teacher-DAT introduced fact
 ‘Taroo introduced Hanako to his new teacher’

On the other hand, the ambiguity of (16) follows if the causee *Taroo* is the embedded subject. When *zibun* is in an embedded sentence, it can take the matrix subject as well as the embedded subject as its antecedent as (18) shows.

- (18) Taroo_i-ga Hanako_j-ni [_{CP} Ziroom_k-ga [zibun_{i,*j,k}-no ie]-ni i-ru to]
 T.-NOM H.-DAT Z.-NOM self-GEN house-at be-Pres. COMP
 it-ta (koto)
 say-Past fact
 ‘Taroo said to Hanako that Ziroom was at his house’

In this example, the matrix subject *Taroo* and the embedded subject *Ziroom* are both possible antecedents of *zibun*.

The verbal complex in (16) has the form, *hihans* ‘criticize’ + (*s*)*ase* ‘cause’ + *ta* ‘Past’. This indicates that the embedded clause lacks T and is a bare *vP* exactly as in the small clause complement of the English (19), as argued by Murasugi and Hashimoto (2004), among others.

- (19) Mary made John criticize her/his teacher

Then, the structure of (16) is as in (20).⁶

⁶ I ignore the matrix CP as it is immaterial for the discussion here. I assume in (20) that the causee *Taroo* moves from the embedded *vP* Spec to an internal argument position of the matrix verb (*s*)*ase* ‘Cause’ in order to receive the causee role. But this assumption does not affect the argument in any way.

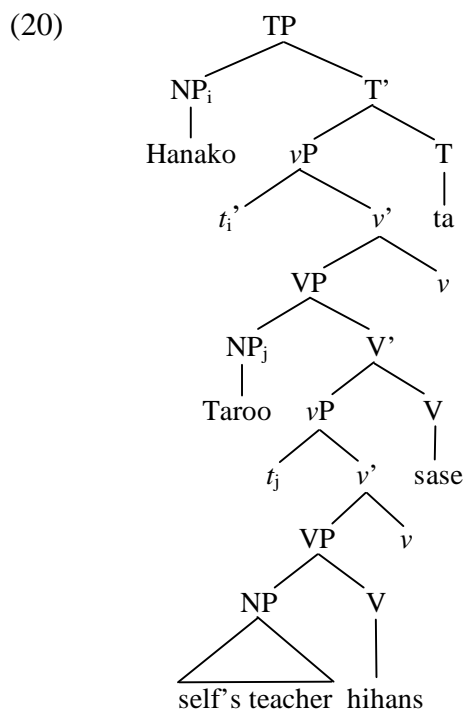

Here, the only position that *Taroo* can possibly acquire a 'subject status' is the embedded vP Spec. The external argument position then must count as a 'subject position' in the relevant sense.

This raises the question whether a generalization can be maintained that possible antecedents of *zibun* are those phrases in vP Spec instead of TP Spec. The answer for this depends on the analysis of unaccusative and passive sentences. As shown in (21), the derived subjects in those sentences qualify as antecedents of *zibun*.

- (21) a. Taroo-ga_i zibun-no ie-de t_i sin-da / koron-da (koto)
 T.-NOM self-GEN house-in die-Past fall.down-Past fact
 'Taroo died/fell down at his house'

- b. Taroo-ga_i karera-niyotte zibun-no ie-de t_i koros-are-ta (koto)
 T.-NOM they-by self-GEN house-in kill-Passive-Past fact
 'Taroo was killed by them at his house'

If *Taroo* in (21a), for example, moves from the object position directly to TP Spec, TP Spec should be included among 'subject positions'. On the other hand, if it moves through vP Spec as in (22), it is possible to restrict the position for antecedents of *zibun* to vP Spec.

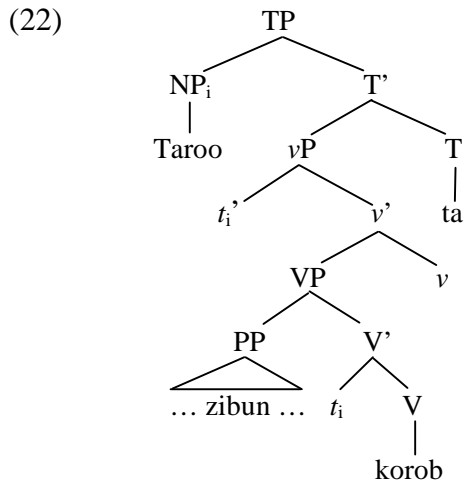

And there is evidence, again from causatives, that the internal argument moves to *vP* Spec in unaccusatives and passives. The causative sentences in (23) contain unaccusative complements and that in (24) a passive complement.

- (23) a. Sono isya-wa Taroo-o zibun-no ie-de sin-ase-te simat-ta
 that doctor-TOP T.-ACC self-GEN house-in die-Cause have-Past
 ‘The doctor has let Taroo die in his own house’
- b. Kaigonin-ga Taroo-o zibun-no heya-de korob-ase-te simat-ta
 caretaker-NOM T.-ACC self-GEN room-in fall.down-Cause have-Past
 ‘The caretaker has let Taroo fall down in his own room’
- (24) Taroo-wa dai-sensei-o zibun-no gakusei-tati-niyotte
 T.-TOP big-professor-ACC self-GEN student-PL-by
 suuhais-are-sase-te oi-ta
 worship-Passive-Cause leave-Past
 ‘Taroo let the big professor be worshiped by his/her students’

In all of these examples, the causee, in addition to the matrix subject, can be the antecedent of *zibun*. (23a) makes sense under this interpretation if the doctor failed to realize the seriousness of Taroo’s condition, and indirectly caused his death by not hospitalizing him and letting him go home. Similarly, (23b) is appropriate when a caretaker was assigned to Taroo so that he does not fall down in his room, but failed to pay sufficient attention to him.

The structure of (23b), for example, should be as in (25).⁷

⁷ (25) indicates the structure with simple past to avoid unnecessary complications.

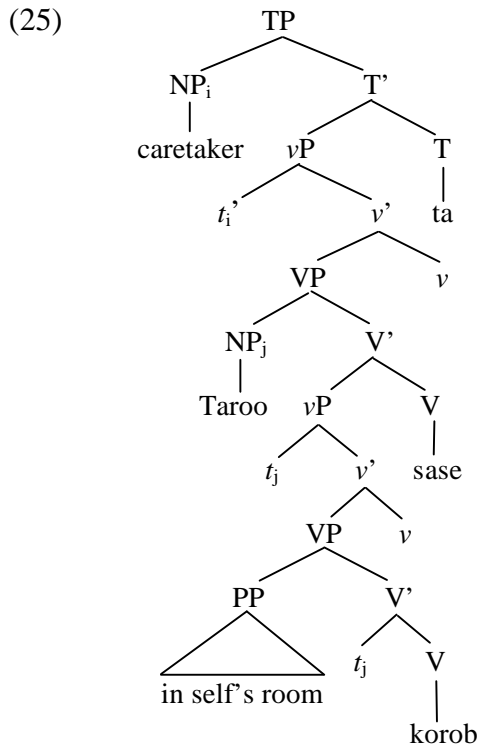

The causee *Taroo* originates in the embedded object position because the embedded verb *korob* ‘fall down’ is unaccusative. It is assumed in (25) that it moves to an internal argument position of the causative verb to receive the causee role. Whether this movement takes place or not, it must move through or to the embedded vP Spec as this is the only position where it can obtain a ‘subject status’. Thus, the example indicates that the object of an unaccusative verb moves to vP Spec. (24) leads to the same conclusion for passive. Then, it can be assumed that the internal arguments qualify as antecedents of *zibun* in the simple unaccusative and passive sentences in (21) because they move through vP Spec.

3.2. vP as a Predication Domain

It has been shown so far that possible antecedents of *zibun* can be restricted to phrases in vP Spec. But the analysis presented above raises a couple of related questions. First, why do the internal arguments of unaccusatives and passives move to vP Spec? Is this simply an optional movement? Or is it necessitated by some feature of v ? Second, scrambling to or through the vP edge does not qualify the moved phrase as the antecedent of *zibun*, as (8), repeated below in (26) with more precise structure, indicates.

- (26) $Taroo_j$ -o [$Hanako_i$ -ga [vP t_j' [vP t_i [VP $zibun_{i,*j}$ -no heya-de t_j sikat-ta]]]]
 T.-ACC H.-NOM self-GEN room-in scold-Past
 ‘Hanako scolded Taroo in her room’

The scrambled phrase *Taroo* is not a possible antecedent for *zibun* as already mentioned above. But this phrase must move through the outer Spec of the vP as the vP is a phase. Thus, the example indicates that neither the final landing site nor the intermediate vP Spec is a

‘subject position’ in the relevant sense. Then, how can the ν P Spec in (25) be distinguished from the intermediate landing site in (26)?

The hypothesis that ν is equipped with an EPP feature provides an answer to both questions. Given this hypothesis, it is possible to define possible antecedents of *zibun* as those phrases that satisfy the EPP requirement of ν . If the verb is transitive or unergative, the external argument is merged with ν and satisfies its EPP requirement. Hence, an external argument qualifies as a ‘subject’ in the relevant sense. If the verb is unaccusative or passive, the EPP feature of ν attracts the internal argument to its Spec. Thus, the derivations in (22) and (25) obtain. The scrambled phrase in (26) moves to the edge of ν P but this has nothing to do with the EPP as the EPP requirement of ν is already satisfied by the external argument. Consequently, scrambling does not create a new ‘subject’.⁸

The final question is why ν has the EPP feature in Japanese. It was argued in the preceding section that feature inheritance from C to T is absent in Japanese as the language lacks ϕ -feature agreement. The same answer can be given here. That is, there is no feature inheritance from ν to V and ν retains the EPP feature for the same reason.

There are further consequences of the analysis just presented. First, it was argued above that not only transitive and unergative ν 's but also unaccusative and passive ν 's have the EPP feature. As mentioned at the outset of this paper, this is in line with Rothstein's (2001) proposal that the EPP reflects the predication relation required in sentential domains. If ν P and CP are two relevant clausal domains, then we would expect a ν P to represent a predication relation even when the verb is unaccusative or passive.

Second, the analysis leads to a prediction for ϕ -feature agreement languages. It is assumed that unaccusative and passive ν 's lack ϕ -features even in those languages. Hence, if the inheritance of the EPP feature is contingent on that of ϕ -features, as argued in this paper, then unaccusative and passive ν 's should retain the EPP feature in those languages, just as in Japanese. There is evidence that seems to support this prediction. For example, the object precedes the passive verb in (27a).

(27) a. There was [a book_i [stolen t_i]]

⁸ The ordering here should follow from Hale and Keyser's (1993) hypothesis that θ -roles are defined on configuration. The lower Spec of ν P, then, should be the locus of the external θ -role.

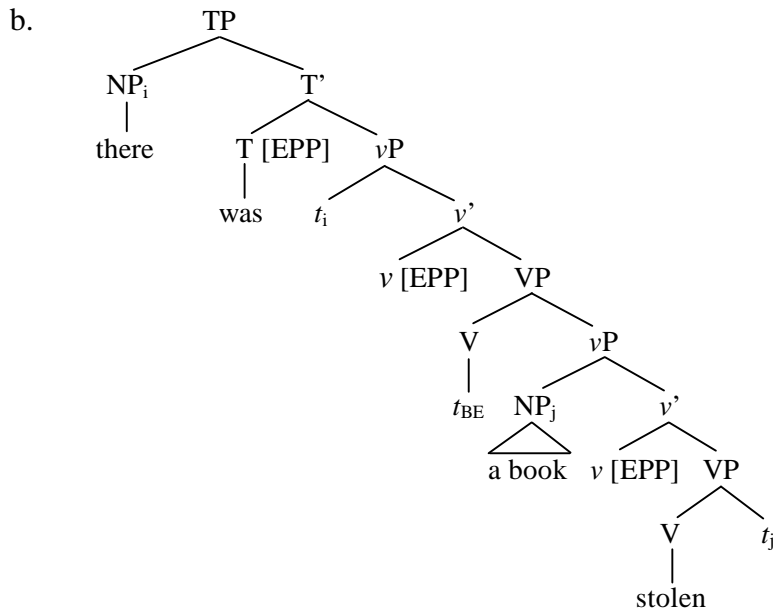

The proposed structure for this example is shown in (27b). The verb *be* is raised to T though *v*. And more importantly for the purpose here, the two *v*'s, one associated with the unaccusative *be* and the other with the passive *stolen*, have the EPP feature. I assume that *there* can satisfy the EPP requirement of the unaccusative *v*. This is necessary for examples like (28a), which should have the structure in (28b).

(28) a. There arrived a man

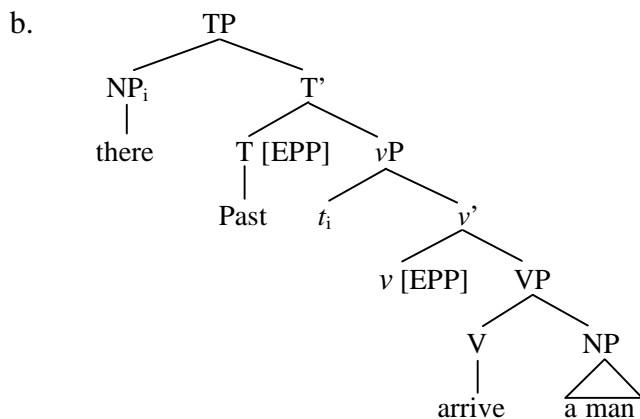

In this example, *there* satisfies the EPP requirement of the unaccusative *v* and raises to TP Spec to check the EPP of T, which was inherited from C. But suppose that passive verbs (in English) have an idiosyncratic property that their associate *v*'s cannot fulfill the EPP requirement by the merger of expletive *there*. Then, as shown in (27b), the internal argument *a book* must raise to the Spec of *v* associated with *stolen* to satisfy the EPP requirement. The peculiar word order in (27a) is thus accounted for.

Finally, the approach provides a clue for the analysis of some mysterious “subjectless sentences” in Japanese, which to my knowledge have resisted a satisfactory description. The examples in (29) are typical examples with dative subjects and nominative objects.

- (29) a. Hanako_i-ni Taroo_j-ga (zibun_{i,*j}-no heya-kara) yoku mi-e-ru (koto)
 H.-DAT T.-NOM self-GEN room-from well see-can-Pres. fact
 ‘Hanako can see Taroo well from her room’
- b. Hanako_i-ni-wa Taroo_j-ga (zibun_{i,*j}-no heya-de) sikari-yasu-i
 H.-DAT-TOP T.-NOM self-GEN room-in scold-easy-Pres.
 ‘It is easy for Hanako to scold Taroo in her room’

As discussed in Kuno (1973), stative predicates allow nominative objects and dative subjects.⁹ The verbal suffix *e* ‘can’ and the adjectival suffix *yasu* ‘easy’ make the predicates stative in (29a) and (29b) respectively. It is widely assumed that the dative phrase is the ‘subject’ as it qualifies as the antecedent of *zibun*. Let us assume, following Bobaljik and Wurmbrand (2007), that the verbal suffix *e* ‘can’ in (29a) takes a VP complement, and following Ura (1999), that the subject is assigned inherent dative in *vP* Spec. Then, the structure of (29a) is roughly as in (30) with the C-projection discussed in the preceding section.

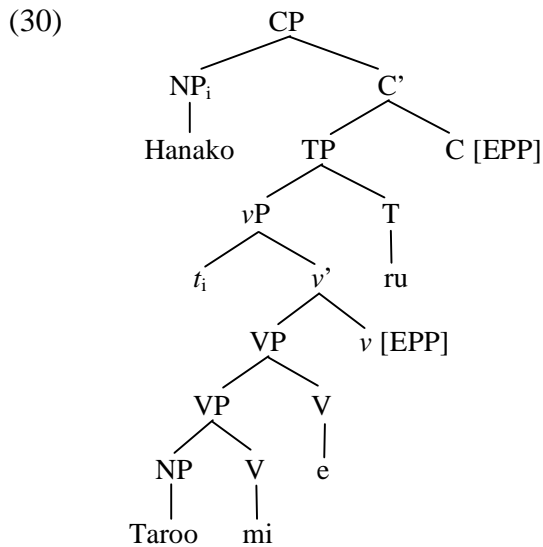

What is curious is that the sentences in (29) sound perfect and complete without the dative subjects. Further, the omission of the dative subject does not make the nominative object a possible antecedent for *zibun*. This is shown in (31).

- (31) a. Taroo_i-ga (*zibun_i-no heya-kara) yoku mi-e-ru (koto)
 T.-NOM self-GEN room-from well see-can-Pres. fact
 ‘Taroo can be seen well (from his room)’

⁹ Actually, only a subset of those predicates allow dative, as opposed to nominative, subjects. For the analysis of this Case marking pattern, see, for example, Kuno (1973), Kuroda (1978), Koizumi (1995), Ura (1999), and M. Takahashi (2010).

- b. Taroo_i-ga (*zibun_i-no heya-de) sikari-yasu-i
 T.-NOM self-GEN room-in scold-easy-Pres.

‘Taroo is easy to scold (in his room)’

Thus, the examples in (31) seem to be without subjects. There is now a way at least to describe this phenomenon. In (30), *e* ‘can’ takes an external experiencer argument. Suppose that this verbal suffix can also be “truly unaccusative,” that is, it can have a lexically idiosyncratic property that it does not take an external argument and its associate *v* lacks an EPP feature. Then, the structure of (31a), for example, is as in (32).

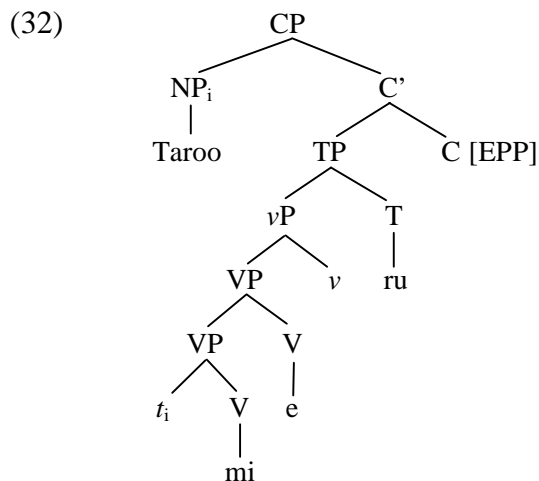

As *Taroo* is the only argument and it does not check the EPP feature of *v*, there is no ‘subject’ in this sentence.¹⁰

4. Conclusion

This paper has reported a preliminary investigation of ‘feature inheritance’ (or its absence) in Japanese. The hypothesis entertained is that feature inheritance applies to ϕ -features, and when this happens, the EPP is ‘pied-piped’. This, coupled with the assumption that there is no ϕ -feature agreement in Japanese, implies that feature inheritance of the EPP does not apply in the language. A few pieces of evidence were presented to show that this prediction is borne out. First, if *C* does not transmit the EPP feature to *T* and retains it, then it is possible to complete Miyagawa’s (2001, 2003) analysis of the subject-negation scope interaction. Second, if *v* retains the EPP without transmitting it to *V*, then the possible antecedents for *zibun* can be properly characterized as those phrases that satisfy the EPP requirement of *v*.

It was argued in the course of the discussion that *v* carries the EPP feature even when it is associated with an unaccusative or passive *V*. This suggests that the distribution of the EPP

¹⁰ “Truly unaccusative” suffixes are exceptional as *v* should normally have the EPP feature. It can be speculated then that they are undergoing “reanalysis” as auxiliaries.

is not confined to phase heads, but reflects predication domains along the lines proposed in Rothstein (2001). Further, when combined with the mechanism of feature inheritance argued for in this paper, it predicts that *v* retains the EPP even in ϕ -feature agreement languages when it is associated with an unaccusative or passive V. This is so because the *v* associated with unaccusatives and passives lacks ϕ -features even in those languages. It was hinted that this prediction might also be borne out.

References

- Bobaljik, J. and S. Wurmbrand (2007) "Complex Predicates, Aspect and Anti-Reconstruction," *Journal of East Asian Linguistics* 16, 27-42.
- Chomsky, N. (2008) "On Phases," in R. Freidin, C. P. Otero and M. L. Zubizarreta, eds., *Foundational Issues in Linguistic Theory: Essay in Honor of Jean-Roger Vergnaud*, MIT Press, Cambridge, Mass., 133-166.
- Hale, K. and S. J. Keyser (1993) "On Argument Structure and the Lexical Expression of Syntactic Relations," in K. Hale and S. J. Keyser, eds., *The View from Building 20: Essays in Linguistics in Honor of Sylvain Bromberger*, MIT Press, Cambridge, Mass., 53-109.
- Koizumi, M. (1995) *Phrase Structure in Minimalist Syntax*, Ph.D. dissertation, MIT.
- Kuno, S. (1973) *The Structure of the Japanese Language*, MIT Press, Cambridge, Mass.
- Kuroda S.-Y. (1965) "Causative Forms in Japanese," *Foundations of Language* 1, 30-50.
- Kuroda, S.-Y. (1978) "Case Marking, Canonical Sentence Patterns, and Counter Equi (A Preliminary Study)," in J. Hinds and I. Howard, eds., *Problems in Japanese Syntax and Semantics*, Kaitakusha, Tokyo, 30-51.
- Kuroda, S.-Y. (1988) "Whether We Agree or Not," *Linguisticae Investigationes* 12, 1-47.
- Miyagawa, S. (2001) "EPP, Scrambling, and Wh-in-situ," in M. Kenstowicz, ed., *Ken Hale: A Life in Language*, MIT Press, Cambridge, Mass., 293-338.
- Miyagawa, S. (2003) "A-Movement Scrambling and Options without Optionality," in S. Karimi, ed., *Word Order and Scrambling*, Blackwell Publishing, Oxford, 177-200.
- Murasugi, K. and T. Hashimoto (2004) "Three Pieces of Acquisition Evidence for the *v*-VP Frame," *Nanzan Linguistics* 1: 1-19.
- Oshima, S. (1979) "Conditions on Rules: Anaphora in Japanese," in G. Bedell, E. Kobayashi, and M. Muraki, eds., *Explorations in Linguistics: Papers in Honor of Kazuko Inoue*, Kenkyusha, Tokyo, 423-448.
- Rizzi, L. (1997) "The Fine Structure of the Left Periphery," in L. Haegeman, ed., *Elements of Grammar*, Kluwer Academic Publishers, Dordrecht, 281-337.
- Rothstein, S. (2001) *Predicates and Their Subjects*, Kluwer Academic Publishers, Dordrecht.
- Saito, M. (2003) "A Derivational Approach to the Interpretation of Scrambling Chains," *Lingua* 113, 481-518.
- Saito, M. (2007) "Notes on East Asian Argument Ellipsis," *Language Research* 43, 203-227.
- Saito, M. (2009) "Optional A-Scrambling," *Japanese/Korean Linguistics* 16, 44-63.
- Saito, M. (2010) "Semantic and Discourse Interpretation of the Japanese Left Periphery," in N. Erteschik-Shir and L. Rochman, eds., *The Sound Patterns of Syntax*, Oxford University Press, Oxford, 140-173.
- Şener, S. and D. Takahashi (2010) "Argument Ellipsis in Japanese and Turkish," in H. Maezawa and A. Yokogoshi, eds., *Proceedings of the 6th Workshop on Altaic Formal Linguistics (WAFSL 6)*, MIT Working Papers in Linguistics 61, 325-339.

- Takahashi, M. (2010) "Case, Phases, and Nominative/Accusative Conversion in Japanese," *Journal of East Asian Linguistics* 19, 319-355.
- Takano, Y. (2010) "Double Complement Unaccusatives in Japanese: Puzzle and Implications," unpublished manuscript, Kinjo Gakuin University.
- Ura, H. (1999) "Checking Theory and Dative Subject Constructions in Japanese and Korean," *Journal of East Asian Linguistics* 8, 223-254.